



# PMC-690A

## Hand-Held Power Quality Analyzer

# PMC-690A



**PMC-690A** is the most advanced and user-friendly Power Quality Analyzer for performing not only ad-hoc real-time monitoring and accurate data recording but also sophisticated Power Quality diagnosis and investigation at site as it combines high accuracy and optimal PQ functions in a Portable, Lightweight and handheld form factor. An extra Android Tablet with pre-installed fully functional App is capable of displaying RMS data, Waveforms and recorded Logs, as well as configurations setup. The PMC-690A complies with standards as IEC 62053-22 Class 0.5S, IEC 61000-4-30 Ed. 3.1 Class A, IEC 61000-4-15, IEC 61000-4-7, EN 50160, IEEE Std 519-2022. Furthermore, the PMC-690A comes with 4xAC/DC Voltage Channel and 4xCurrent (3xAC + 1xAC/DC) Channel, dual 10/100/1000BaseT Ethernet ports, 1xBuilt-in full band 4G LTE modem and 1x802.11n Wi-Fi Module (supporting both Station and Access Point modes) for Internet or tablet connectivity. In addition, it offers 2xDI, 2xSS Pulse Output and 4xAUX Analog DC Input for 2xDC Voltage and 2xDC Current channel.

## Typical Applications

### Utility

- PQ Check-up at HV, MV & LV Utility Substations
- Site Investigation & Diagnosis for PQ problems

### Industrial and Commercial

- Electrical Testing and Recording
- Fault Investigation and Identification
- No Load and Full Load Test Mains and Critical Feeder Dips, Swells, Transients, Flicker and Disturbance Monitoring
- 400Hz line measurement for use in avionics and shipboard

## Basic Features

- IEC 62053-22 Class 0.5S kWh metering
- True RMS @ 2048 samples/cycle
- AC/DC Input Measurement with Split Core Current Clamps or Rogowski Coils
- Intuitive Interface and simple configurations
- Replaceable Lithium Battery for 8-hour runtime
- 128GB on-board eMMC and optional 512GB TF card for Log memory
- Industrial-grade, 2.3" Backlit Color TFT LCD @ 320x240
- SNTP, IEEE 1588, IRIG-B/GPS 1PPS Input and GNSS Time Sync. (GNSS Antenna ordered separately)

## Power Quality Features

- IEC 61000-4-30 Ed. 3.1 Class A compliant
- EN 50160 and IEEE Std 519-2022 Reporting
- Dips, Swells, Interruptions, Transients, Rapid Voltage Change, Inrush Current, Mains Signalling Voltage and Flickers monitoring- Real-time Waveform Capture (WFC), Waveform Recording (WFR) & Disturbance Waveform Recording (DWR) in COMTRADE File format
- Disturbance Direction Indicator for Dips, Swells and Interruptions
- Statistical Data Recording and ½ cycle RMS Recording

## PQ Monitor (HD App on Tablet)

- True RMS Real-time, Harmonics, Power and Energy Measurements
- Phasor Diagram, Harmonics & Interharmonics Histogram, 2kHz-150kHz C.E.
- Real-time WFC of 3-phase U & I @ 128 samples/cycle
- Event WF Display @ max. 2048 samples/cycle & ITIC/SEMI F47 Curves
- Trend Curves for DR and SDR Logs
- Max. & Min. Logs
- EN 50160 and IEEE Std 519-2022 reports
- Deviation, Sequence Components & Unbalance
- Device Logs, SOE Logs, PQ Counters and I/O Status
- Device Configuration and Diagnostics

## Power Quality Metering

### PQ Parameters as per IEC 61000-4-30 Ed. 3.1 Class A Compliant

- Power Frequency
- Magnitude of the Supply Voltage and Current
- Flicker
- Supply Voltage Interruptions, Dips and Swells
- Transient Voltages
- Supply Voltage Unbalance and Current Unbalance
- Harmonics and Interharmonics for Voltage and Current

# Hand-Held Power

- Mains Signalling Voltage on the Supply Voltage
- Rapid Voltage Change
- Voltage Over/Under Deviation and Frequency Deviation
- Inrush Current
- 2kHz to 150kHz Conducted Emission Measurements

## Harmonic and Interharmonic Measurements

- U and I THD, TOHD, TEHD, TIHD, TOIHD, TEIHD and TH (RMS)
- Current TDD, TDD Odd and TDD Even
- U and I Individual Harmonics (%HD and RMS) from 2<sup>nd</sup> to 63<sup>rd</sup>#
- K-Factor for Current, Crest Factor for Current and Voltage
- U and I Individual Interharmonics (%IHD and RMS) from 1<sup>st</sup> to 63<sup>rd</sup>#
- Fundamental U, I, P, Q, S Phase Angle and Displacement PF
- Harmonic Phase Angle from 2<sup>nd</sup> to 63<sup>rd</sup>
- U and I DC Components
- Real-time U and I Harmonic Components (RMS) from 5Hz to 3150Hz

# %HD and %IHD can be configured as % of Fundamental, % of U/I nominal or % of RMS

## Conducted Emissions in the 2kHz to 150kHz Range

- Real-time amplitude (3s) and the Max., Min., Avg. and CP95 (in 1-minute interval) for Voltage channels with a total of 106 frequency segments (2kHz-150kHz) and Current channels with a total of 35 frequency segments (2kHz-9kHz)

## Sequence and Unbalance

- Zero, Positive and Negative Sequence Components
- U and I Unbalance based on Zero and Negative Sequence Components

## Dips, Swells, Interruptions Recording

- Dips, Swells and Interruptions detection @ 10ms (½ cycle at 50Hz)
- Trigger for SOE Log, DR, WFR, DWR, RMSR and iTrigger
- Display of Event specific WFR, DWR and/or RMSR as well as the associated ITIC/SEMI F47 plot on PQ Monitor app

## Transients Recording

- Standard transients capture as short as 10µs @ 50Hz or 8.33µs @ 60Hz for sub-cycle disturbances such as capacitor switching and resonance phenomena
- 2MHz sampling capacity for 0.5µs high-speed Transients detection and synchronous waveform recording
- Trigger for SOE Log, WFR, DWR, RMSR and iTrigger
- Display of Event specific WFR, DWR and/or RMSR on PQ Monitor app

## Rapid Voltage Change (RVC)

- Detection of a quick transition in RMS Voltage between two steady-states

## Inrush Current Monitoring

- Monitoring of the ½ cycle RMS Current and capturing of the Current waveforms associated with events such as motor starting and transformer being energized

## Disturbance Direction Indicator

- Determine if a PQ Event is located upstream or downstream

- Pinpoint if the cause of the event is external or internal

## PQ Event Counters

- Dips, Swells, Interruptions, Transients, Rapid Voltage Change, Inrush Currents, Mains Signalling Voltages and Total PQ Event Counters during monitoring period

## Metering

### Basic Measurements (1-second update)

- 3-phase U, I, P, Q, S and PF as well as U4, I4 (Measured Neutral Current) and Frequency

### Energy

- Per-phase kWh, kvarh Import/Export/Net/Total and kVAh Total
- Total RMS kWh, kvarh Import/Export/Net/Total and kVAh Total
- Total Fundamental kWh, kvarh Import/Export/Net/Total
- Total Harmonic kWh, kvarh Import/Export/Net/Total and Harmonic kWh, kvarh Import/Export from 2<sup>nd</sup> to 63<sup>rd</sup>

### Demands

- Present and Predicted Demand for 3-phase U, I, P, Q, S and PF as well as U4, I4, Frequency
- Present Demand of 4-phase U & I THD/TOHD/TEHD, 4-phase Current K-Factor, U2/U0 & I2/I0 Unbalance, Over & Under Deviation of Voltage and Frequency, 4-phase Fundamental Current
- Max./Min. values per Demand Interval
- Maximum Demands for This Month & Last Month (or Since Last Reset & Before Last Reset)
- Demand Synchronization with DI

## Setpoints

### PQ Setpoints

- Transients, Dips, Swells, Interruptions, Rapid Voltage Change, Inrush Current
- Trigger DO, DR, SOE Log, WFR, DWR, RMSR and iTrigger

### Control Setpoint

- 40 Standard (1s) and/or High-Speed (1 cycle) Control Setpoints can be configured with extensive monitoring sources including U, I, Freq., P, Q, S, PF, Harmonics, Unbalances, Deviations, Flickers, Phase Reversal/Loss, AI and etc.
- Configurable thresholds and time delays
- Trigger DO, DR, SOE Log, WFR, DWR, RMSR and iTrigger

### Digital Input Setpoint

- Provides Control Output Actions in response to changes in DI status
- Trigger DR, SOE Log, WFR, DWR, RMSR and iTrigger

### Motor Start Setpoints

- Monitoring motor startup procedure with recording of Max. Starting Current, Minimum Voltage and Duration
- Trigger DO, SOE Log, WFR, DWR and iTrigger

# Quality Analyzer

## Data and Event Recorders

### Non-Volatile Log Memory

- 128GB on-board eMMC and optional 512GB TF card for Log memory

### SOE Log

- Max. 1024 events per day on the basis of FIFO
- Time-stamped to  $\pm 1$ ms resolution
- Setpoint event, I/O operation, Dips, Swells, Interruptions, Transients, Rapid Voltage Change, Inrush Current, Mains Signaling Voltage, iTrigger, etc.
- Record the characteristic data for Setpoint events as well as WFR, DWR, RMSR, ITIC and/or SEMI F47 Curve for PQ events
- Stop when monitoring period ends

### Device Log

- Max. 1024 events per day on the basis of FIFO
- Time-stamped to  $\pm 1$ ms resolution
- Power On/Off, Setup changes, Time Sync., Device Operations and Self-diagnostics
- Stop when monitoring period ends

### Statistical Data Recorder (SDR)

- Recording of the Max., Min., Avg. and 95<sup>th</sup> percentile values for all retrievable measurement with a 150-cycle integration interval on the basis of FIFO
- Recording Interval from 1 to 60 minutes
- Logging sessions and period depending on user configuration
- Downloadable via PQ Monitor app or iPQ Software

### Data Recorder (DR)

- 2 DR Logs recording 2-hour parameters @ 10min and 2h interval respectively
- 1 DR Log Recording of max. 512 configurable parameters on the basis of FIFO
- Configurable Recording Offset and Interval from 1s to 1 day
- Logging sessions and period depending on user requirements

### Trend Curve for SDR and DR

- Trend display of recorded SDR and DR parameters via PQ Monitor app
- Ability to export the logs in tabular form

### Max./Min. Recorder (MMR)

- 1 Max./Min. Recorders of 80 parameters each
- Metering for RMS/Fundamental/Harmonic/Interharmonic Measurements, Deviations, Unbalances and Flicker during monitoring period

### Interval Energy Recorder (IER) and Accumulative Energy Recorder (AER)

- Both IER Log and AER Log support the recording of per-phase and Total RMS kWh, kvarh Import/Export/Total/Net and kVAh Total, Total Fundamental and Total Harmonic kWh, kvarh Import/Export during monitoring period
- Recording Interval from 1 minute to 65,535 minutes
- Max. Recording Depth @ 65,535 records for each group

- Stop when monitoring period ends

### 5Hz Spectrum Recording

- 3 groups recording of 20 consecutive Voltage/Current Harmonic Components with 5Hz bins resolution
- Stop when monitoring period ends

### Real-Time Waveform Capture (WFC) and Waveform Recorder (WFR)

- Real-time WF Capture @ 128 samples/cycle
- WFR @ Max. 1500 entries per day on the basis of FIFO
- Simultaneous capture of 4-phase Voltage and 4-phase Current Inputs
- (Range of Cycles) x Samples/Cycles with programmable pre-fault and post-fault cycles:
  - 50Hz/60Hz: (40-200) x 2048, (40-400) x 1024, (40-800) x 512, (40-1600) x 256, (40-3200) x 128
  - 400Hz: (40-200) x 256, (40-400) x 128, (40-800) x 64, (40-1600) x 32, (40-3200) x 16
- Scheduled WFR with max. repetition of 10,000 times and programmable schedule from 1 to 960 hours
- Continuous Waveform Recording during monitoring period @ 128 samples/cycle stored in TF card (~13GB/day) on the basis of stop-when-full mode
- 2M samples/second Waveform Recording for High-speed Transient capture with max. 100 entries per day on the basis of FIFO
- COMTRADE file format, downloadable through PQ Monitor App

### Disturbance Waveform Recorder (DWR)

- Max. 1500 entries per day on the basis of FIFO
- Logging sessions and period depending on user requirements
- Simultaneous recording of all Voltage (U1-U4) and Current (I1-I4) Inputs
  - Initial Fault: 35 cycles @ 512 samples/cycle
  - Extended Fault: Up to 150 cycles @ 16 samples/cycle
  - Steady State: Up to 360s of 1-cycle absolute peak values
  - Post Fault: 15 cycles @ 512 samples/cycle

### RMS Recorder (RMSR)

- Max. 1500 entries per day on the basis of FIFO
- 16 channels max., selectable U, I, P, Q, S, PF, Frequency, Freq. Deviation
- Recording Interval from 0.5 to 60 cycles
- Recording Width @ 7200 samples per parameter
- Configurable pre-fault samples from 100 to 500
- 72 seconds of 1/2 cycle RMS recording @ 50Hz or 60 seconds @ 60Hz

### iTrigger

- Cross trigger DO, SOE Log, WFR, DWR and RMSR with other devices iTrigger within the same local area network (LAN)
- Group ID and MAC Address provided as the trigger source



# PMC-690A

## IEEE Std 519-2022 Report

- 365 Daily Reports for statistical evaluations on Voltage and Current Harmonics based on 99th percentile very short time (3 s) values
- 52 Weekly Reports for statistical evaluations on Voltage Harmonics (95th percentile) and Current Harmonics (95th and 99th percentile) short time (10 min) values
- Programmable settings for Report Mode, PCC Voltage, Max. Short Circuit Current, etc.

## Inputs and Outputs

### Digital Inputs

- 2 channels, volts free dry contact, 24VDC internally wetted
- 1000Hz sampling for status monitoring with programmable debounce
- Pulse counting with programmable weight for each channel for collecting WAGES (Water, Air, Gas, Electricity, Steam) information

### Solid State Pulse Outputs

- Standard 2 channels SS Relays for Energy Pulsing applications

### Auxiliary Analog Inputs

- 2xVoltage(0-10VDC) and 2xCURRENT (0/4-20mA DC) channels with user programmable displayed units

## Communications

### Ethernet Port (P1, P2)

- Dual 10/100/1000BaseT Ethernet Ports with RJ45 connector

### Wi-Fi Module

- 802.11n Wi-Fi support configurable access point mode (connect to tablet) or station mode (connect to Internet)

### 4G

- Built-in 4G LTE CAT4 modem supports MQTT protocol
- Uplink speed: max. 50Mbps, Downlink speed: max. 150Mbps
- Certified Carrier including Deutsche Telecom, Verizon, AT&T, Sprint, US Cellular, T-Mobile, Telus, Rogers and etc.
- Frequency bands supported:
  - 4G LTE: B1/B2/B3/B4/B5/B7/B8/B12/B13/B18/B19/B20/B25/B26/B28/B38/B39/B40/B41
  - 3G UMTS: B1/B2/B4/B5/B6/B8/B19

### USB Port

- USB 2.0 type A port for USB flash drive to transfer data and for tablet auxiliary power supply and communications
- USB 2.0 type C port for data downloaded to PC

## Time Synchronization

- Battery-backed Real-time clock @ 6ppm ( $\leq 0.5s/day$ )
- Time Sync. with auto-selection among Modbus RTU, GNSS Receiver, SNTP, IEEE 1588 and GPS 1PPS/IRIG-B

## System Integration

### PQ Monitor Application (Pre-installed HD App on Tablet)

- The PMC-690A is supported by CET's PQ Monitor (HD App).
- The PQ Monitor supports
  - Intuitive display of Real-time Measurement and Historical Monitoring Record
  - Management for Monitoring Record
  - Graphic (Waveform, ITIC and SEMI F47 and Trend Curve) analysis for the measurements
  - Export for IER, AER, DR and SDR Logs as well as EN50160, IEEE Std 519-2022 and user-defined reports
  - Templated Configuration for all Setup parameters

### iPQ Explore

- Compact, password protected, free Windows software for simultaneous connection to multiple Power Quality Analyzers
- Support configuration of all Setup parameters
- Display Real-time Measurements, PQ Events and Waveform Analysis
- Trend display of recorded DR, SDR, IER and AER
- Ability to export trend curve in PNG format and log in tabular format
- Generation of EN 50160 and IEEE Std 519-2022 Reports in Excel and PDF format

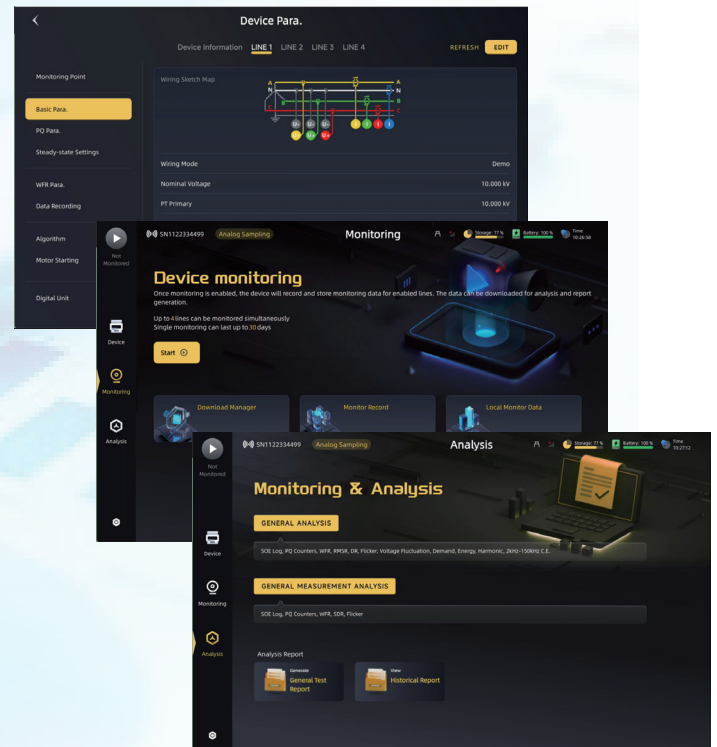

# Accuracy

Parameters	Accuracy	Resolution
Voltage (U)	±0.1%	0.001V
I1, I2, I3, I4	±0.1% + Error of SCCP/Rogowski Coil	0.001A
P/Q/S	±0.2% + Error of SCCP/Rogowski Coil	0.001kX
kWh, kVAh	IEC 62053-22 Class 0.5S	0.001k
kvarh	IEC 62053-24 Class 0.5S	0.001k
Phase Angle	Fundamental: ±0.2°, Harmonic: ±5°	0.1°
Freq., Freq. Deviation	±0.001Hz	0.001Hz
Harmonics, Interharmonics	IEC 61000-4-7 Class I	0.01%
U Unbalance	±0.1%	0.01%
I Unbalance	±0.5%	0.01%
Pst, Plt	IEC 61000-4-15 Class F1	0.001
Analog Input	±0.5%	0.001

Note: The accuracy will be different under 400Hz line measurement. Please contact CET for more information.

# Technical Specifications

## Voltage Inputs ~ (CH1, CH2, CH3, CH4)

Standard (Un)	400VLN/690VLL + 20%
Range	5-1000Vrms or 5-1000VDC
Starting Voltage	4V
Overload	1000Vrms continuous, 2500Vpk for 1s
Burden	< 0.1VA/per phase
PT Ratio	
Primary	1-999,000V
Secondary	1-1,500V
Measurement Category	CAT IV 600V, CAT III 1000V
Resolution	18-bit A/D
Frequency	40-72Hz, 320-480Hz (400Hz system)

## High-speed Voltage Transients (CH1, CH2, CH3)

Range	±4kV
Sampling Rate	2MHz
Resolution	14-bit A/D
Trigger	Adjustable threshold x Un (%)

## Current Inputs (CH1~, CH2~, CH3~, CH4~) via SCCP/Rogowski Coil

CH1, CH2 and CH3 Input (In)	0-500mV from SCCP/Rogowski Coil
PMC-SCCP-50A-500mV-L-A-B	AC 5A/50A
PMC-SCCP-500A-500mV-L-B-B	AC 500A
PMC-SCCP-5kA-500mV-L-C-C-254	AC 500A/5kA
PMC-SCCP-5kA-500mV-L-C-C-371	AC 500A/5kA
CH4 Input	0-100mA from SCCP
PMC-SCCP-50A-20mA-L-X-B	AC/DC 50A
PMC-SCCP-500A-20mA-L-X-B	AC/DC 500A
CT Ratio	
Primary	1-30,000A
Secondary	1-50A
I4 Primary	1-30,000A
I4 Secondary	1-50A

## Power Supply (L/+, N/-)

Adapter Input	100-240VAC ± 10%, 50Hz/60Hz
Adapter Output	12VDC/5A
UPS	Replaceable Lithium battery (8-hour runtime, 10-hour charge time)

## Digital Inputs (DIC, DI1, DI2)

Standard	Dry contact, 24VDC internally wetted
Sampling	1000Hz
Hysteresis	1ms minimum

## GPS Input (CLK+, CLK-)

Accuracy	GPS 1pps/IRIG-B: < 1ms, IEEE 1588: < 1ms
----------	--

## GNSS Time Sync. (ANT)

Connector Type	SMA Male
Reception Capability	GPS L1 C/A
Accuracy	< 55us

## Solid State Pulse Outputs (E1+, E1-, E2+, E2-)

Type	Form A Solid State Relay
Isolation	Optical
Max. Load Voltage	30VDC
Max. Forward Current	100mA

## Analog Input (AUX)

A11/AI3 Type	0/4-20mA Current
A12/AI4 Type	0-10VDC Voltage
Overload	24mA or 12VDC

## Environmental Conditions

Operating Temperature	-10°C to 50°C
Storage Temperature	-40°C to 70°C
Humidity	5% to 95% non-condensing
Atmospheric Pressure	70 kPa to 106 kPa
Pollution Degree	2

## Mechanical Characteristics

Unit Dimensions	324.4x233.5x73.8 mm
IP Rating	51

# Standard of Compliance

## Safety Requirements

CE LVD 2014/35/EU	EN 61010-1: 2010 + A1: 2019 EN IEC 61010-2-030: 2021
Electrical Safety in Low Voltage Distribution Systems up to 1000Vac and 1500 Vdc	IEC 61557-12: 2021 (PMD)
Insulation AC Voltage Insulation Resistance Impulse Voltage	EN 61010-1: 2010 + A1: 2019 2kV @ 1 minute >100MΩ 6kV, 1.2/50μs

# EMC Compatibility

CE EMC Directive 2014/30/EU (EN IEC 61326: 2021)

## Immunity (EN50082-2)

Electrostatic Discharge	EN 61000-4-2: 2009
Radiated Fields	EN IEC 61000-4-3: 2020
Fast Transients	EN 61000-4-4: 2012
Surges	EN 61000-4-5: 2014 + A1: 2017
Conducted Disturbances	EN IEC 61000-4-6: 2023
Magnetic Fields	EN 61000-4-8: 2010
Voltage Dips and Interruptions	EN IEC 61000-4-11: 2020
Ring Wave	EN 61000-4-12: 2017

## Emission (EN50081-2)

Limits and Methods of Measurement of Electromagnetic Disturbance Characteristics of Industrial, Scientific and Medical (ISM) Radio-Frequency Equipment	EN 55011: 2016 + A1: 2017 + A2: 2021
Electromagnetic compatibility of multimedia equipment - Emission Requirements	EN 55032: 2015 + AC: 2016 + A11: 2020
Limits for Harmonic Current Emissions for Equipment with Rated Current ≤ 16 A	EN IEC 61000-3-2: 2019 + A1: 2021
Limitation of Voltage Fluctuations and Flicker in Low-Voltage Supply Systems for Equipment with Rated Current ≤ 16 A	EN 61000-3-3: 2013 + A1: 2019 + A2: 2021
Emission Standard for Industrial Environments	EN IEC 61000-6-4: 2019

## Mechanical Tests

Spring Hammer Test	IEC 62052-31: 2015
Vibration Test	IEC 62052-11: 2020
Shock Test	IEC 62052-11: 2020

## Power Quality

Voltage Characteristics of Electricity Supplied by Public Distribution Systems	EN 50160: 2022
General Guide on Harmonic and Interharmonic Measurements and Instrumentation, for Power Supply Systems and Equipment Connected Thereto	IEC 61000-4-7: 2009
Flickermeter-Functional and Design Specifications	IEC 61000-4-15: 2010
Testing and Measurement Techniques-Power Quality Measurement Methods	IEC 61000-4-30: 2021 Ed. 3.1
Power Quality Measurement in Power Supply Systems - Part 2: Functional Tests and Uncertainty Requirements	IEC 62586-2: 2021 Ed. 2.1

## Ordering Information

### Product Code

### Description

PMC-690A Hand-Held Power Quality Analyzer

Basic Function	A	<ul style="list-style-type: none"> <li>Conformances to IEC 62053-22: 2020 Class 0.5S for active energy accuracy and IEC 61000-4-30 Ed.3.1 Class A for Power Quality measurement.</li> <li>4xVoltage Input (CAT IV 600V/CAT III 1000V), 4xCurrent Input (500mv Max.)</li> <li>2x 10/100/1000BaseT Ethernet Port, 1x USB 2.0 Type A and 1x USB 2.0 Type C Port, 1x Built-in full band 4G LTE Modem, 1x Wi-Fi Module with 802.11n support for access point/station mode</li> <li>2MHz High-Speed Transient, 400Hz System Measurement, 2K~150KHz C.E.</li> <li>Waveform Recording (Max. 2048 Sample/Cycle) &amp; Continuous Waveform Recording Function* (128 Sample/Cycle)</li> <li>2x DI (Dry Contact, 24VDC internally wetted), 2x SS Pulse Output</li> <li>Time Synchronization (SNTP, IEEE 1588, IRIG-B/GPS 1PPS and GNSS~)</li> <li>Cascade Sampling Synchronization (for Multiple Devices)</li> <li>1xReplaceable Lithium Battery with 8-hour runtime</li> </ul>
Sample Mode	A	Analog Sampling
External Display	X	None
Language	E	English
PMC-690A		PMC-690A-AAXE (Standard Model)

\* The continuous waveform recording function requires the optional 512G TF card.  
 ~ The GNSS Antenna should be ordered separately.  
 ^ External Display (Tablet) is not included. Customers may use their own tablets.  
 Please contact CET to confirm whether the tablet model is compatible with the PQ Monitor app.

## Dimensions and Installation

Unit: mm

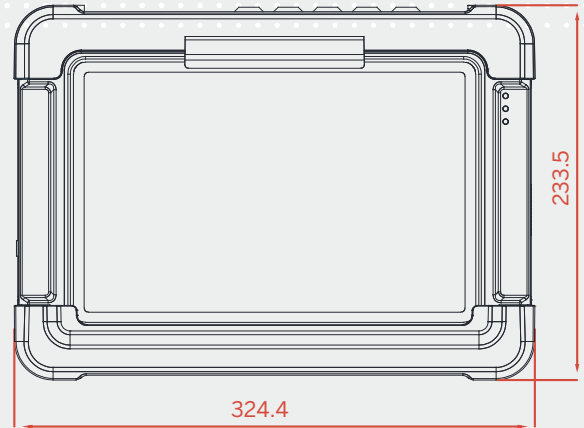

## Interface & Terminal Diagram

T1 Voltage Inputs  
 T2 Current Inputs  
 T3 AUX (Analog) Inputs  
 T4 Chassis Ground



Top Interface

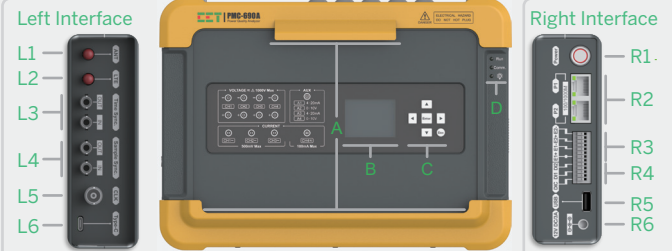

L1 GNSS Antenna (SMA) Connector  
 L2 4G LTE Antenna (SMA) Connector  
 L3 Time Sync. Input/Output  
 L4 Sample Sync. Input/Output  
 L5 IRIG-B/GPS 1PPS Input  
 L6 USB 2.0 Type C Connector

A Brackets for Tablet  
 B TFT LCD Display  
 C Function Key  
 D LED Indicators

R1 Power Button  
 R2 10/100/1000BaseT Ethernet Ports  
 R3 Solid State Pulse Outputs  
 R4 Digital Inputs  
 R5 USB 2.0 Type A Connector  
 R6 Power Adapter Input

## Typical Wiring Diagram

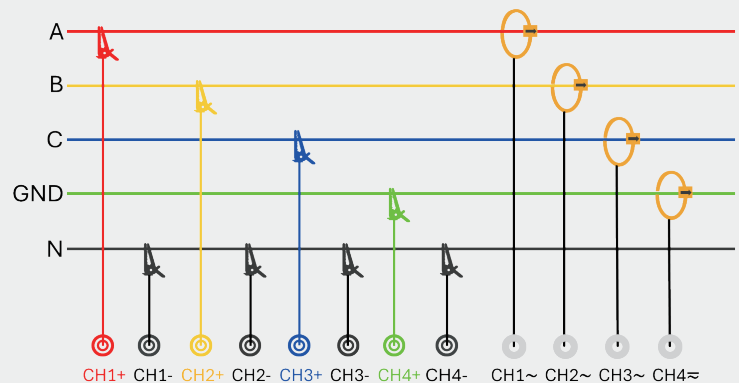

3P4W WYE Connection

# Accessories

## Cables

### Adapter Cable

1m adapter cable for BNC Male to Dual Alligator Clips-for IRIG-B/GPS 1PPS Input (Red for Positive Input, Black for Negative Input) Alligator Clip Jaw Opening: 10mm



### Ethernet Cable

Two sets of 2m Flat CAT6 Ethernet cable with RJ45 connectors



### ST Fiber Optic Jumper

Two sets of 3m ST Fiber Optic Jumper cable-for Sync. of Time/Sampling between interconnected PMC-690A



### Adapter Cable

0.57m adapter cable for BNC Male to 4 pairs of Alligator Clips-for Auxiliary Analog DC Inputs-2xVoltage Input + 2xCURRENT Input (Red for Positive Input, Black for Negative Input) Alligator Clip Jaw Opening: 10mm



## Test Leads

### Voltage Test Lead Sets

4xVoltage Test Leads - color coordinated, safety shrouded, 4mm stackable Banana Plug on both ends of the leads, 3m length



### Neutral Voltage Test Lead

4 sets of Neutral Voltage Test Lead - Black, safety shrouded, 4mm non-stackable Plug on both ends of the leads, 3m length



### Test Lead

3 sets of Test Lead - Black, safety shrouded, 4mm stackable Banana Plug on both ends of the leads, 0.25m length



### Test Lead

Test Lead-Blue, safety shrouded, 4mm non-stackable Banana Plug on both ends of the leads, 2m length



## Optional CT Clamps

**PMC-SCCP-50A-500mV-L-A-B**, L=3m or 20m, Ø15mm  
In=AC 5A/50A, Max.Allowable Current=50A  
Output=10mV/A (Max.500mv), Accuracy: ±0.3% rdg., ±0.02%f.s  
Protection: CAT III 300V  
Termination: Ø14 Circular Push-Pull Connector



**PMC-SCCP-50A-500mV-L-A-B**, L=3m, Ø8mm  
In=AC 50A, Max.Allowable Current=50A  
Output=10mV/A (Max.500mv), Accuracy: ±0.2% rdg., ±0.02%f.s  
Protection: CAT III 300V  
Termination: Ø14 Circular Push-Pull Connector



**PMC-SCCP-500A-500mV-L-B-B**, L=3m, Ø50mm  
In=AC 500A, Max.Allowable Current=500A  
Output=1mV/A (Max.500mv), Accuracy: ±0.5% rdg., ±0.02%f.s  
Protection: CAT III 600V  
Termination: Ø14 Circular Push-Pull Connector



**PMC-SCCP-50A-20mA-L-X-D** In=AC/DC 50A, Max.Allowable Current=50A  
**PMC-SCCP-500A-20mA-L-X-D** In=AC/DC 500A, Max.Allowable Current=500A  
Output=Max. 20mA, Accuracy: ±1%f.s.  
Protection: CATIII 600V  
L=2M, Ø63mm, Termination: Ø14 Circular Push-Pull Connector



## Bag

**Waterproof Nylon Bag**  
445x145x350mm (WxHxD)



## Clips & Plugs

### Alligator Clips

8xAlligator Clips with 4mm Banana Jack, Jaw opening: 27mm Length: 83.5mm Max. Current: 10A



### Plug pin and Adapter

4 Pairs (Black and Red), 4mm Banana Jack to 2mm Pin Tip Plug Adapter (1)  
4 Pairs (Black and Red), 4mm Banana Jack to 4mm Banana Plug Adapter (2)  
4 Pairs (Black and Red), 4mm Banana Jack to M3 Thread Stud Adapter (3)

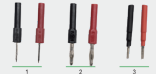

## Flexible Rogowski Coil

**PMC-SCCP-5ka-500mV-L-C-C-254**, L=2m, Ø254mm

**PMC-SCCP-5ka-500mV-L-C-C-371**, L=2m, Ø371mm

In=AC 500A/5kA, Max. Allowable Current=5.5kA  
Output=AC 1mV/A @ 500A, AC 0.1mV/A @ 5kA (Max.5V)

Accuracy=±2.0% rdg., Protection: CAT III 1000V/CAT IV 600V  
Termination: Ø14 Circular Push-Pull Connector



## Adapter

### 60W AC Power Adapter for PMC-690A Main Unit

- Input: 100-240VAC, 50/60Hz
- Output: 12VDC, 5A
- AC Input Cord Length: 1m
- DC Output Cord Length: 1.8m
- Plug Type: Type I



## Antenna

Dual 4G SMA antenna kit: 1xRubber Duck Antenna, 1xMagnetic-Mount Antenna with 3m cable

### Rubber Duck Antenna

Frequency Range: 2400-2500MHz  
Band Width: 100MHz  
VSWR: ≤ 2.0, Gain: 2.5-3 dBi  
Power: 50W



### Magnetic-mount Antenna

Frequency Range: 824-960/1710-2700 MHz  
Band Width: 136/990MHz  
VSWR: ≤ 3.0, Gain: 3.0dBi  
Power: 50W



### Optional Magnetic-mount GNSS Antenna

Frequency Range: 1561-1576 MHz  
Band Width: 15MHz  
VSWR: ≤ 2.0, Gain: 28±3 dBi



Email: [sales@cet-global.com](mailto:sales@cet-global.com)

Website: [www.cet-global.com](http://www.cet-global.com)

Copyright © CET Inc. All rights reserved.

Your Local Representative

V.00 03.18.2026